

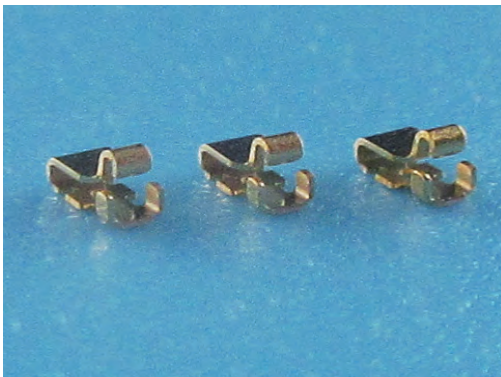

Onboard Contact

OG-160810S

NEW



Tiny profile, board-level
EMC grounding component

- Compact design, great for space-conscious applications (such as smart, wearable devices)
- Au plating for stable contact resistance
- Tape-and-reel design for automated mounting

Specifications

Applications	SMT spring contact
Rated current	3A
Recommended Gap (mm)	0.7 ~ 0.9
Material	Beryllium copper
Surface Treatment	Partial Au plating (Ni undercoat)
Operating Temperature (°C)	-40 ~ 125

Application examples



Suitable for devices which are designed to be small and highly dense. Such as wireless earphones, smart glasses, dash-cams, smart phones, tablet PCs etc.

OG-160810S

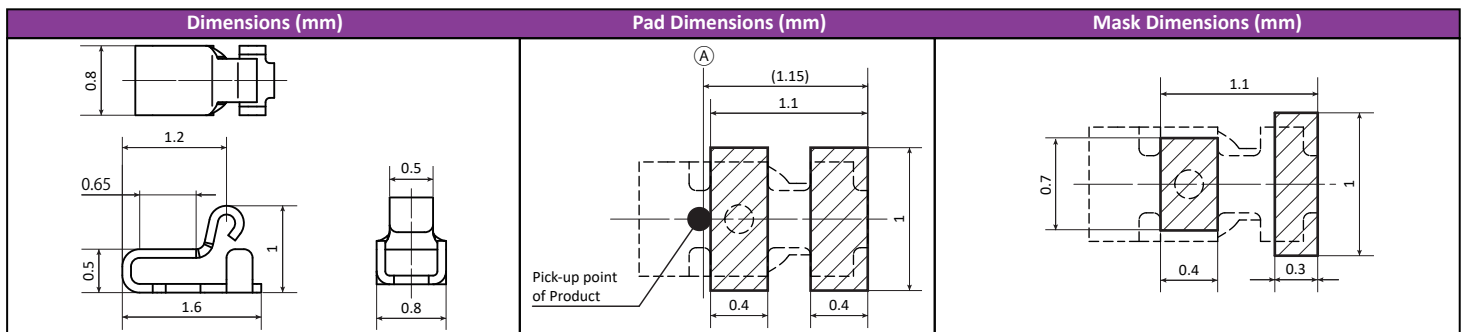

Properties

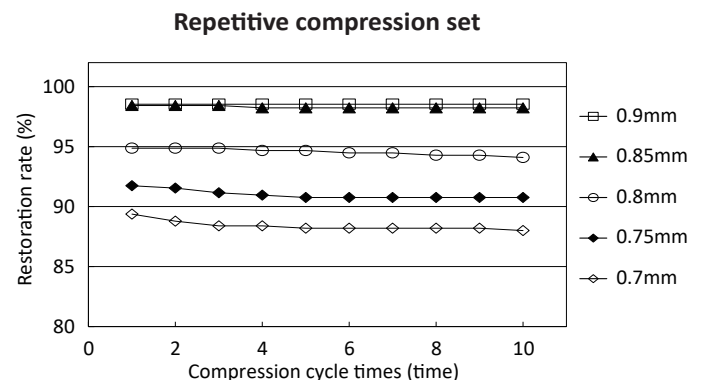
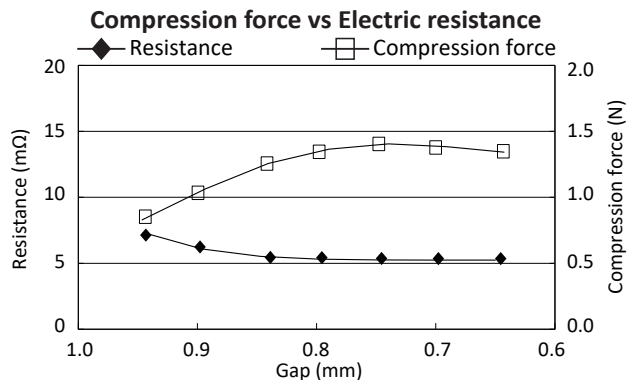

Tel: 1-855-EMC-PART (1-855-362-7278) Email: sales@kgs-ind.com

Please request for detailed product specification data prior to purchase

All statements, specifications, properties, technical information, and recommendations herein are based on tests; however, the accuracy and completeness are not guaranteed and are subject to change without notice due to product improvement and specification change. This statement is made in lieu of all warranties, expressed or implied, including the implied warranties of marketability, and fitness for purpose. KITAGAWA INDUSTRIES America, Inc. obligation under this warranty shall be limited to replacement of product that proves to be defective. Prior to use, the user shall determine the suitability of the product for its intended use, and the user assumes all risk and liability whatsoever in connection therewith. KITAGAWA INDUSTRIES America, Inc. shall have no liability for any injury, loss, or damage arising out of the use of or the inability to use the products. No statement or recommendation contained herein shall have any force or effect unless in an agreement signed by officers of seller and manufacturer. Reprinting or copying any content in KGS America catalogs is strictly prohibited without prior consent. KITAGAWA INDUSTRIES America, Inc. logos and markings are registered trademarks of KITAGAWA INDUSTRIES America, Inc. (dba KGS America) or an affiliate company thereof. KGS America logo may not be used or copied under any circumstances.

Please contact the sales department at KITAGAWA INDUSTRIES America, Inc. for the use of our products prior to selecting the parts for your application.

www.kgs-ind.com

Onboard Contact_OG-160810S_REV0_03072023