

EMC Technical Seminar

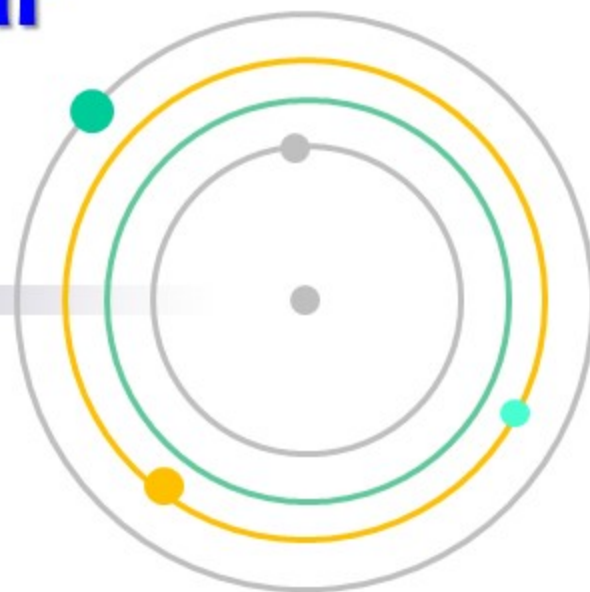

All statements, specifications, properties, technical information, and recommendations herein are based on tests; however, the accuracy and completeness are not guaranteed and are subject to change without notice due to product improvement and specification change. This statement is made in lieu of all warranties, expressed or implied, including the implied warranties of marketability, and fitness for purpose. KITAGAWA INDUSTRIES America, Inc. obligation under this warranty shall be limited to replacement of product that proves to be defective. Prior to use, the user shall determine the suitability of the product for its intended use, and the user assumes all risk and liability whatsoever in connection therewith. KITAGAWA INDUSTRIES America, Inc. shall have no liability for any injury, loss, or damage arising out of the use of or the inability to use the products. No statement or recommendation contained herein shall have any force or effect unless in an agreement signed by officers of seller and manufacturer.

Please contact the sales department at KITAGAWA INDUSTRIES America, Inc. for the use of our products prior to selecting the parts for your application.

© Copyright 2019 KITAGAWA INDUSTRIES America, Inc. All Rights Reserved.

Please note that KITAGAWA INDUSTRIES America, Inc. Logo, and other marks are subject of trade marks or registered trade marks of KITAGAWA INDUSTRIES America, Inc. or an affiliate company thereof. KITAGAWA INDUSTRIES America, Inc. reserves other intellectual property rights and nothing herein provides a license under any KITAGAWA INDUSTRIES America, Inc. or any third party intellectual property rights.

Contents

1. Fundamentals of EMC
2. Shielding Techniques and Components
3. Grounding Techniques and Components
4. Filtering Techniques with Ferrite Cores

What is EMC?

EMC: **E**lectro-**M**agnetic **C**ompatibility



EUT: Equipment Under Test

EMI: **E**lectro-**M**agnetic **I**nterference

- Radiated disturbance
- Conducted disturbance

EMS: **E**lectro-**M**agnetic **S**usceptibility

- Radiated immunity
- Conducted immunity

Daily Life filled with Electromagnetic energy

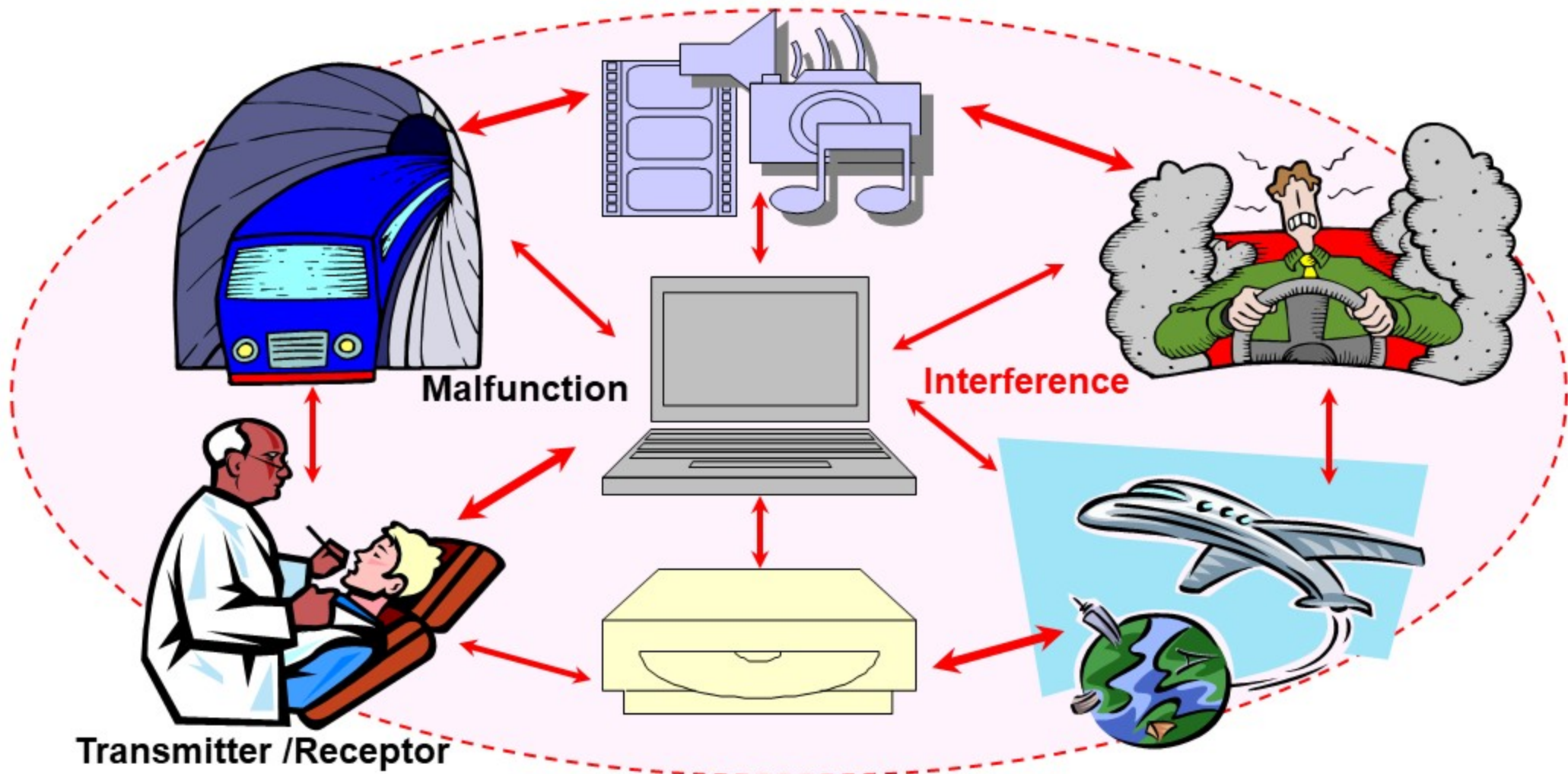

EMC Suppression



EMI Noise Measurement (demo)

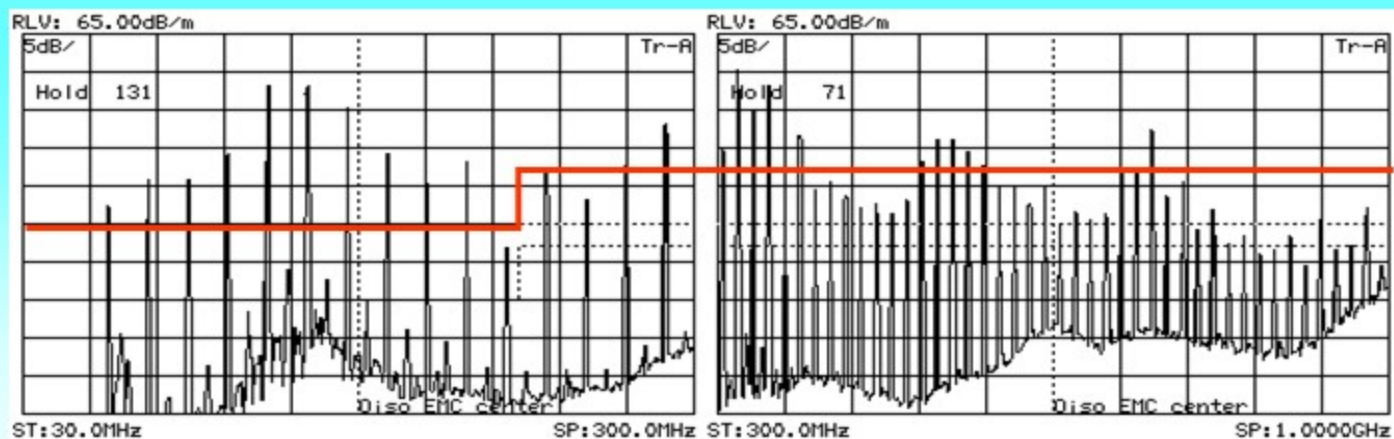
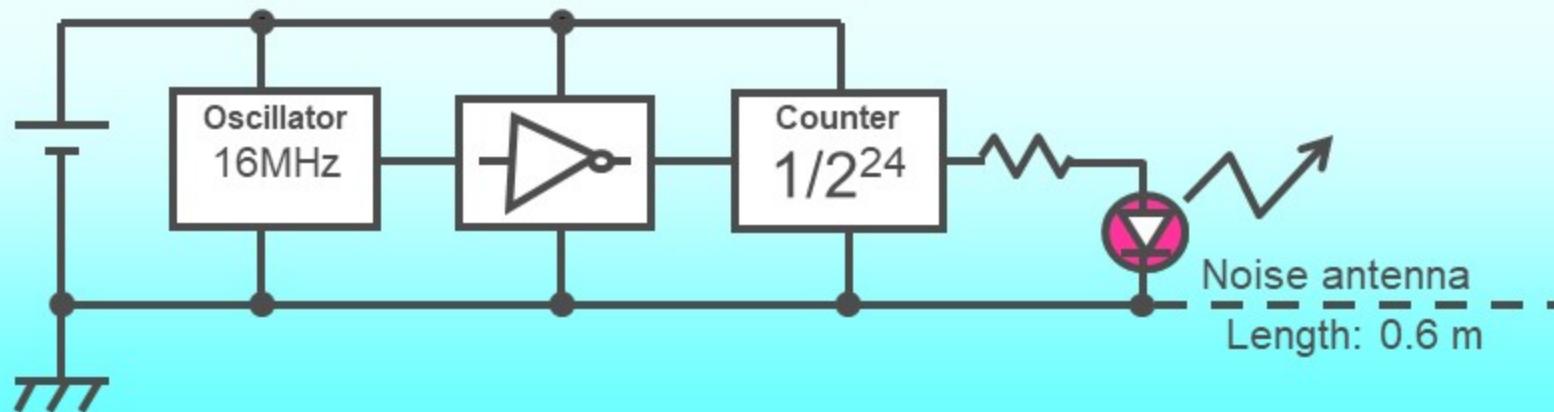

Electric field strength radiated from noise generator

Common Mode Noise

Field strength generated by common mode current (distance: 10m)

$$E_C = 4\pi \times 10^{-7} \frac{I_C \cdot f \cdot L}{d}$$

$$= 60\text{dB } \mu\text{V/m}$$

$$(L : 0.7\text{m}, d : 10\text{m}, f : 320\text{MHz})$$

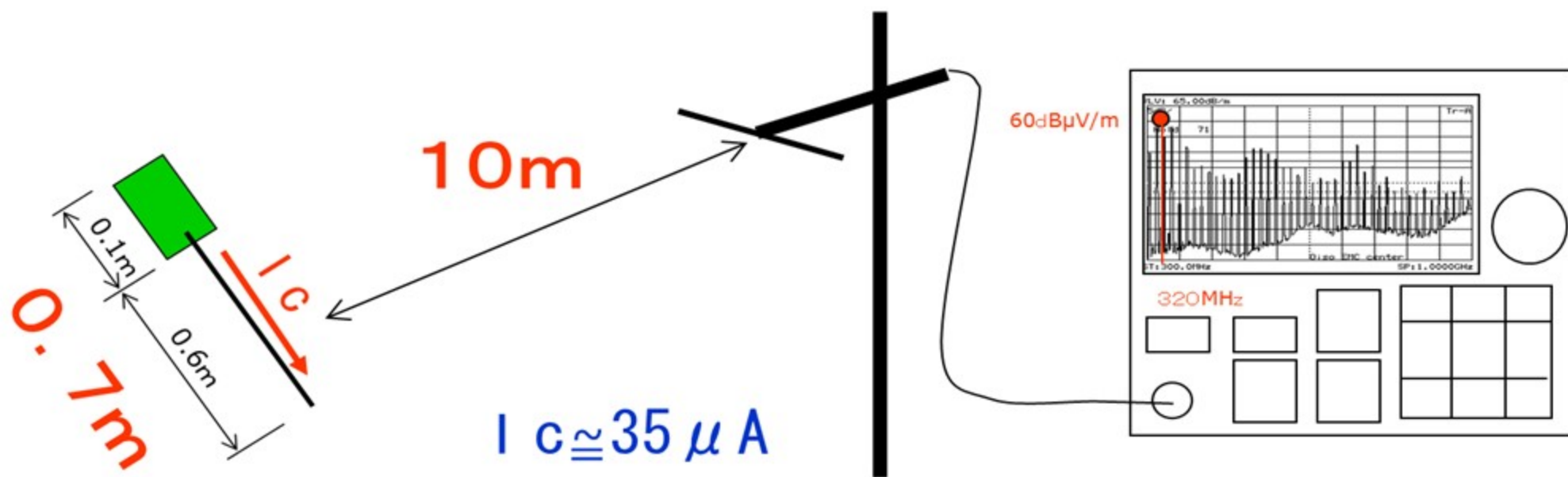

Component Solutions

Grounding



Shielding



Filtering



Wide variety of electric components, EMC solutions

EMC compliance
measurement
EMC design support
Technical seminar

Thermal management
Vibration control

Total Component Solutions

In Review: Grounding

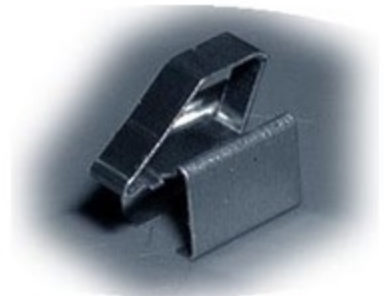
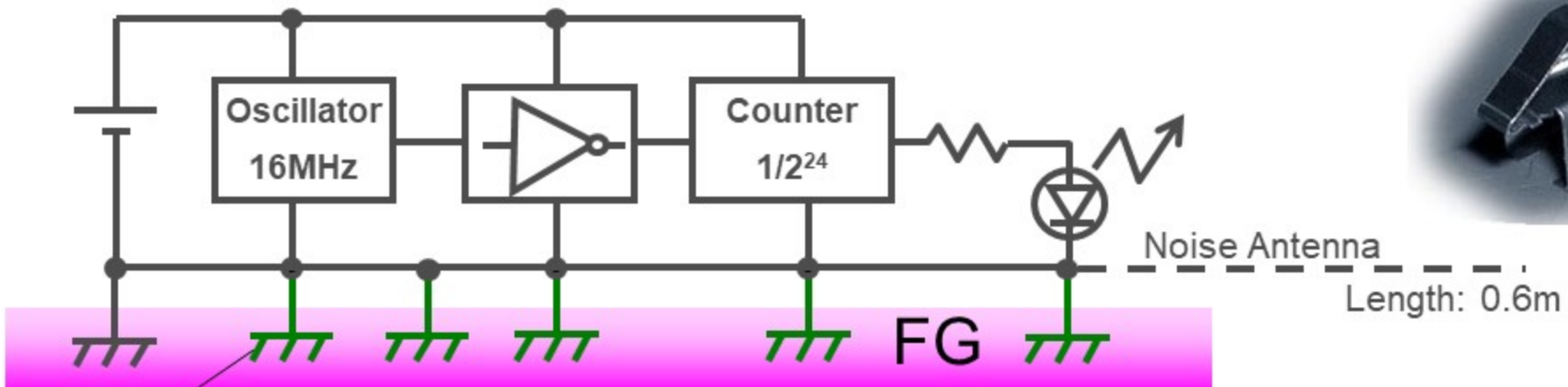

Grounding with lower impedance

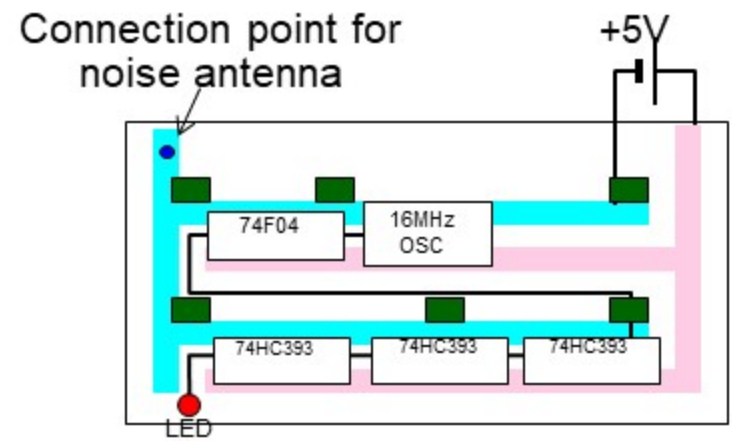

- Vcc
- Ground
- Grounding to FG with 6 pieces of on-board ground contacts

Noise Suppression with Grounding Contacts

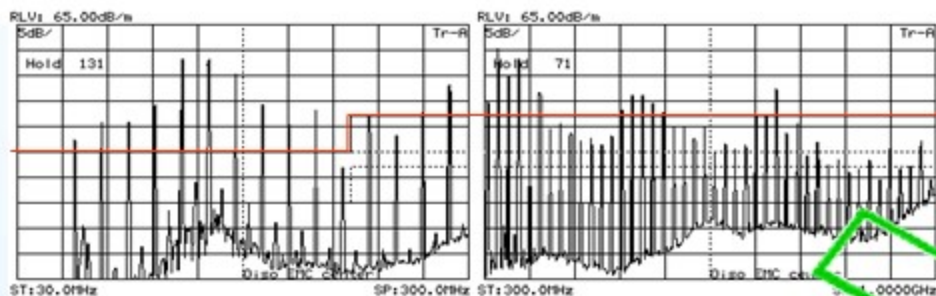

Multiple grounding points
enhance noise suppression

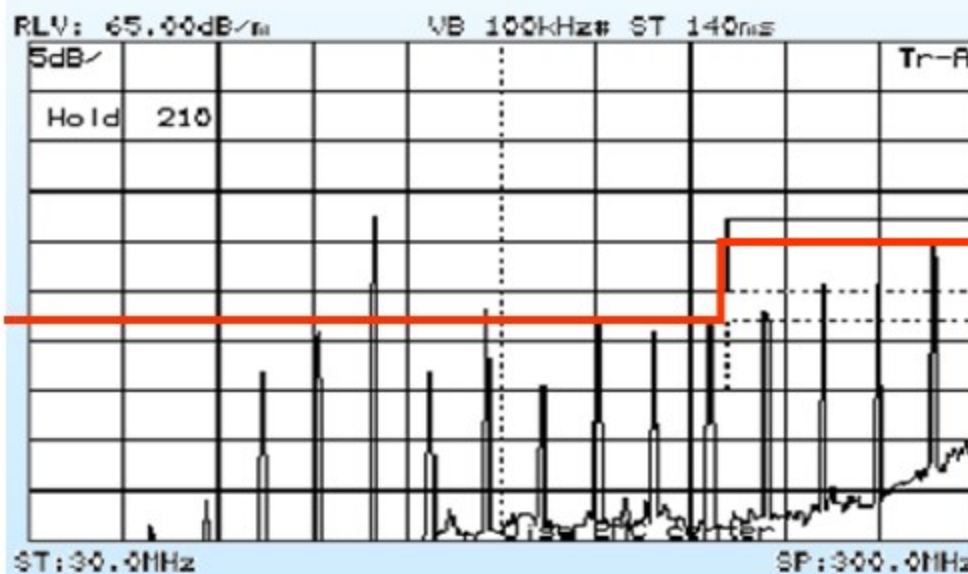

There would be little to no effect with ferrite cores in the higher frequency range;
however, a striking effect can be observed with grounding in this area.

Combination of Grounding and Filtering

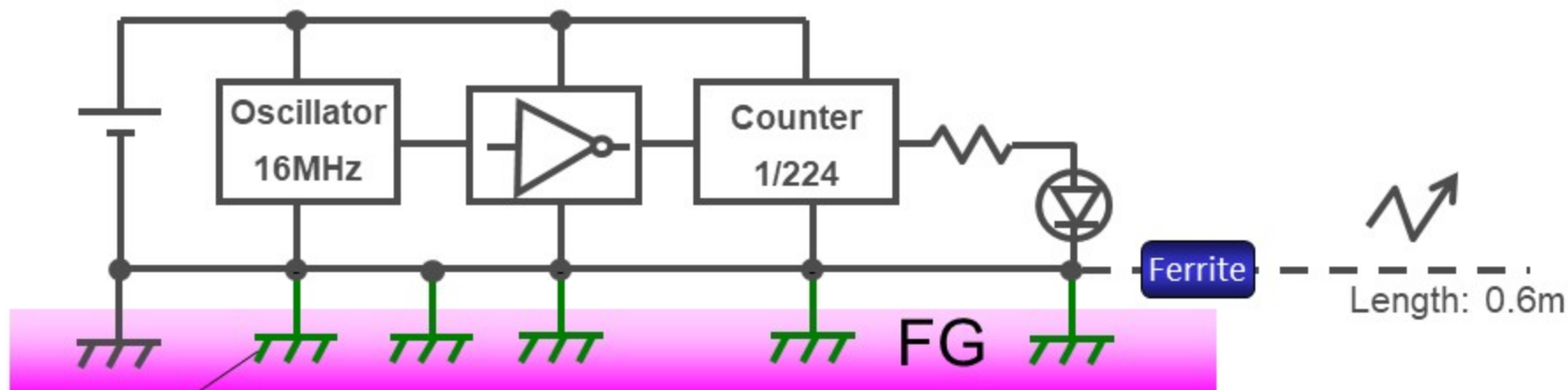

Connection point for noise antenna

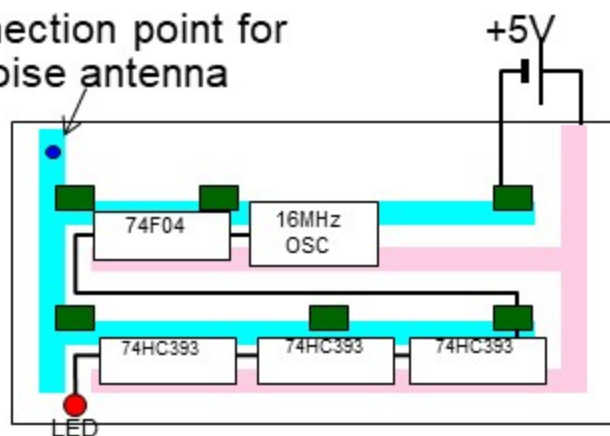

Vcc

Ground

Grounding to FG with 6 pieces of on-board ground contacts

Combination of Grounding and Filtering

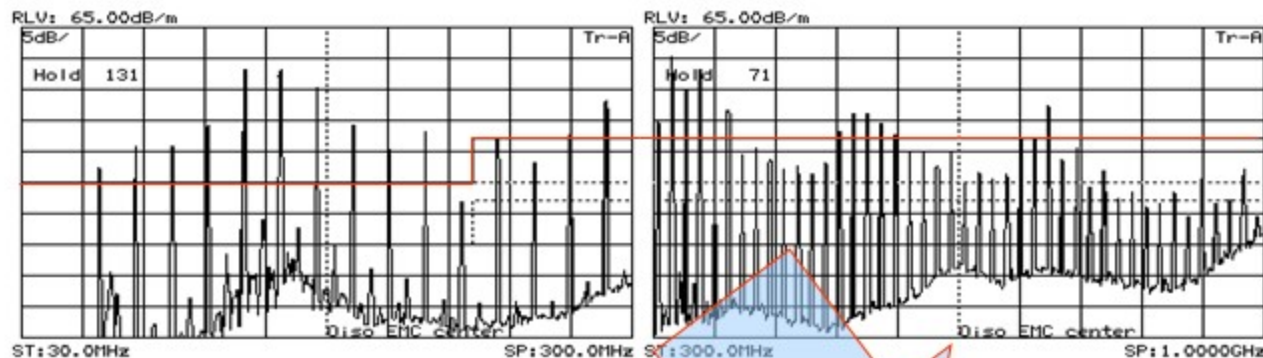

Achieved broadband noise suppression!

